

Product Catalogue



Email: sales@actisense.com

Call: +44 (0)1202 746682



Member of
SUPERYACHT UK



Lloyd's Register
LRQA

Actisense®

Actisense®

Award Winning NMEA Specialists

Making your voyage safer by giving you greater control of data on your vessel's network.



Our range of products are developed to industry standards and to a high level of quality and technical sophistication.

'With our excellent customer and technical support, we offer the products and service you would expect from an industry leading brand.'

We take great pride in our intelligent design and exacting manufacturing standards, ensuring the products we develop are the products you want and need.'

- Phil Whitehurst CEO

Contents

NMEA 2000:

Introduction	3
Product Range	5

NMEA Software 11

A2K Range:

Introduction	15
Product Range	17

PRO Range 19

NMEA 0183:

Introduction	25
Product Range	27

Product Accessories 33

NEW @

Actisense®

Smart Universal Micro Terminator



Part Number: A2K-TER-U

Introducing the world's first intelligent universal inline terminator.

Terminate your NMEA 2000 network – regardless whether a male or female connection is required – and use the TER-U's smart functionality to easily diagnose any power or voltage issues on your NMEA 2000 bus.

The TER-U can be fitted directly at the end of your network or used as an in-line terminator in difficult to access locations.

NMEA 2000® Micro Smart Starter Kit

The Actisense NMEA 2000 Smart Starter Kit has everything you might need for a seamless NMEA 2000 installation. The kit includes:

2 Smart Universal Micro Terminator's - to terminate your NMEA 2000 network and easily diagnose any power or voltage issues on your NMEA 2000 bus

A Micro Power T - to power the network

2 Micro T-pieces - to allow two NMEA 2000 devices to connect to the network

NMEA 2000 Lite cable assembly 4 metre – to extend the distance between any two network pieces



Part Number: A2K-KIT-4



NMEA 2000® Range

NMEA 2000® Network Diagram

Building your NMEA 2000 network with Actisense products

The simplicity of installing a single cable that contains both power and data is an attractive benefit to help reduce costs.

Actisense has been actively helping to develop and promote the NMEA 2000 Standard since designing one of the very first NMEA 2000 products in 2004. The experience amassed over the NMEA 2000's lifetime is clear to see throughout the Actisense NMEA 2000 product range and our commitment to support the NMEA with future developments will allow that to continue.

Actisense NMEA 2000 intelligent products are all NMEA 2000 Certified and our NMEA 2000 network products are all NMEA 2000 Approved, so you can relax knowing that you have Actisense onboard.

Our Research and Development team created two powerful NMEA 2000 Gateways that have served the industry for more than 10 years; one that makes the transition from NMEA 0183 to NMEA 2000 as smooth as possible and the other that can be an NMEA 2000 network diagnostic tool one minute and third-party PC application interface the next. The team has also developed an Engine Monitoring Unit for converting analogue sensor signals into NMEA 2000 and a Wi-Fi Gateway for sharing NMEA 2000 data wirelessly to mobile applications whilst logging NMEA 2000 data to its SD card.

What is NMEA 2000®?

NMEA 2000 was designed using the knowledge learned from more than 20 years of NMEA 0183 installations to create a new marine Standard that was safer, more reliable and easier to use. With a bandwidth 50 times greater than NMEA 0183, a far larger volume of data can be shared between a much wider diversity of devices.

Low-powered NMEA 2000 devices can be powered directly from the backbone network cable to greatly improve power distribution - only high-powered devices require their own dedicated power connection.

NMEA 2000 devices can be plugged and unplugged quickly and easily using the standard DeviceNet 'plug & play' connectors.

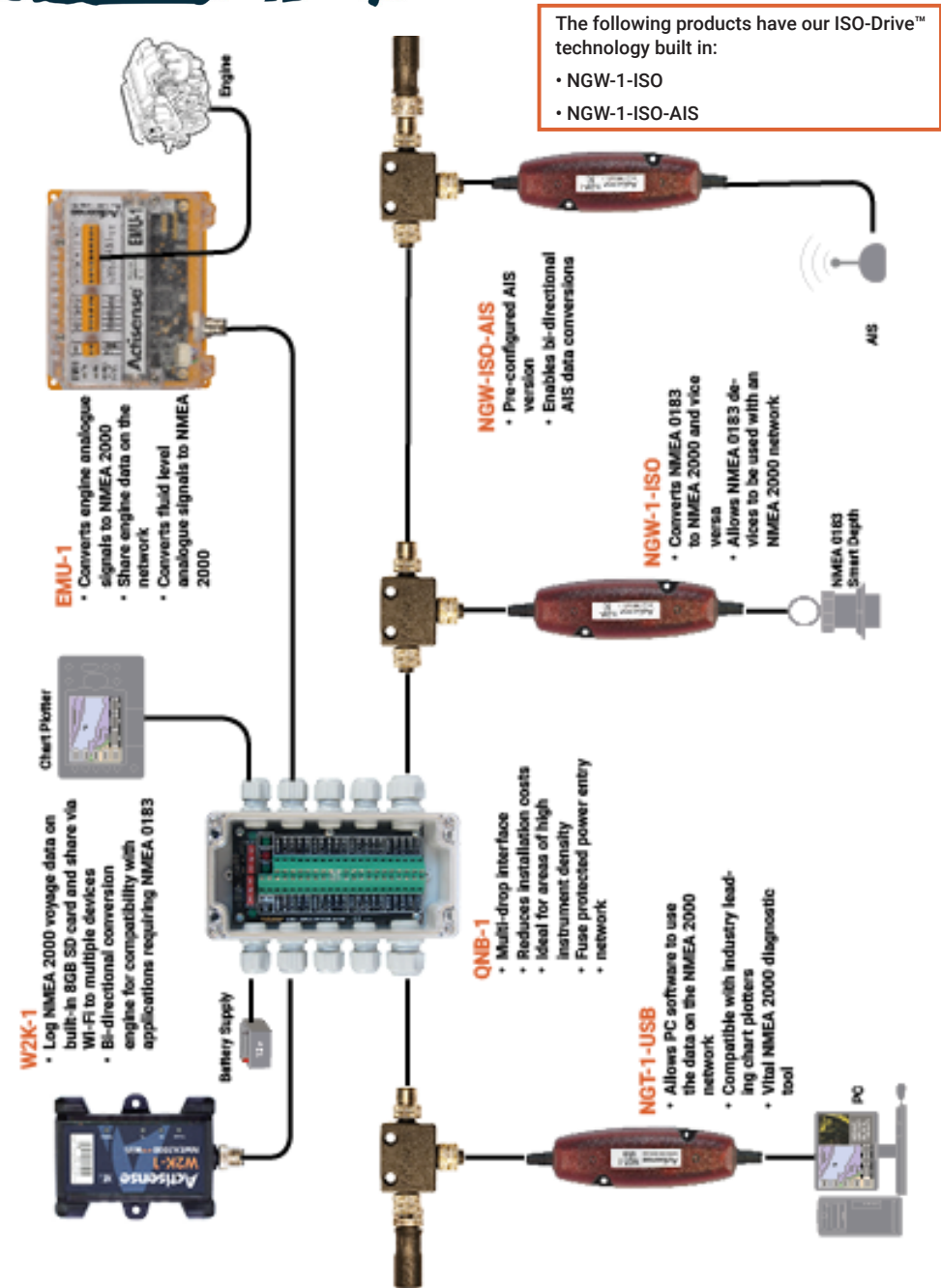

The following products have our ISO-Drive™ technology built in:

- NGW-1-ISO
- NGW-1-ISO-AIS



W2K-1

NMEA 2000® to Wi-Fi Gateway

The W2K-1 is a rugged and reliable NMEA 2000 to Wi-Fi Gateway with built-in data logger.

It transfers data from an NMEA 2000 backbone to devices (e.g. laptops, tablets or smartphones) connected via Wi-Fi and additionally can convert this data to NMEA 0183 using Actisense's renowned conversion engine.

This allows a wide variety of vessel data to be shared with a large number of compatible applications. All data is automatically logged to its built in high reliability microSD card providing approximately 16 days¹ recording which is ideal for analysing race data, generating logbooks, diagnosing problems or even sharing your voyage details.

The W2K-1 has the legendary Actisense "Reliability Built In" along with useful diagnostic LEDs, internal antenna, enhanced password security, full certification and all packaged in an extremely rugged IP67 case.

¹ Bus load dependant – can vary between 6 and 100 days

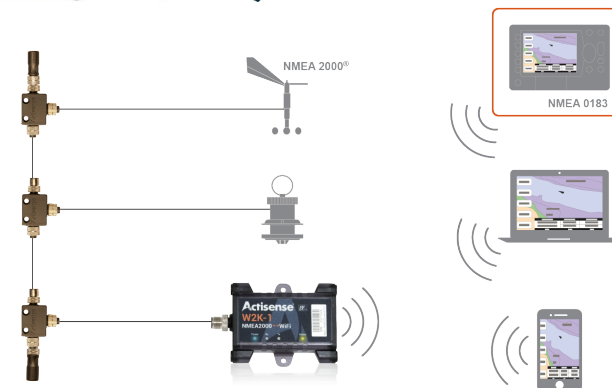

Benefits

Two-in-one NMEA 2000 to Wi-Fi Gateway and data logger

Enables use of mobile devices and laptops without the hassle of a physical connection

Allows compatibility with a wide range of NMEA 2000 & NMEA 0183 applications

Ruggedised IP67 casing suitable for wet and harsh environments

Works out of the box with pre-installed industrial grade SD card

Integrated antenna has less chance of physical damage

Quick and easy to install

Features

Converts NMEA 2000 to/from NMEA 0183 (streamed over Wi-Fi)

Supports both TCP and UDP, streams data using up to three separate data servers

Data protocols are selectable to be compatible with a huge range of navigation software and apps

Approximately 16 days of Voyage data recording (upgradable)

Diagnostic LEDs for NMEA 2000 bus activity and Wi-Fi Status

Works as an access point and client simultaneously

Remote Firmware upgradability

Low power- 2 LEN (100 mA)

Supports 802.11 b/g/h (up to 150Mbps)

Automatically measures and reports the NMEA 2000 bus voltage

User Manual embedded on the device, easily accessible via browser

Each device has unique default SSID and Password for enhanced security



EMU-1

Engine Monitoring Unit

Part Number: EMU-1



NGT-1

NMEA 2000® to PC Interface

Part Numbers: NGT-1-USB
NGT-1-ISO

Share engine information on the NMEA 2000 bus.

The EMU-1 enables the sharing of engine data throughout the NMEA 2000 bus. It digitises analogue engine sensors, enabling NMEA 2000 display devices to monitor the connected engine(s) on a vessel.

Each EMU-1 can be configured to suit the engine it is working with, offering a flexible solution for multiple engine makes and models. Capable of reading a wide range of engine parameters, the EMU-1 will report how the engine is operating and share the information across the network.

Benefits

- No need to change an existing engine
- Easy installation
- Easy to configure to suit the connected engine
- Connect signals from fluid level gauges (that share a common ground with the engine) to NMEA 2000®
- Optional DIN rail mounting kit available
- Total engine hours are logged by the monitoring of engine Tach (RPM) input



Enables analogue signals to be converted to NMEA 2000 messages

Convert signals from up to two engines (that share a common ground) with a single EMU-1

6 gauge / parameter inputs

4 alarm inputs

2 additional auxiliary inputs

2 Tacho inputs

Customised IP65 case

Diagnostic LED's

Wide power compatibility of 9 to 35 Vdc

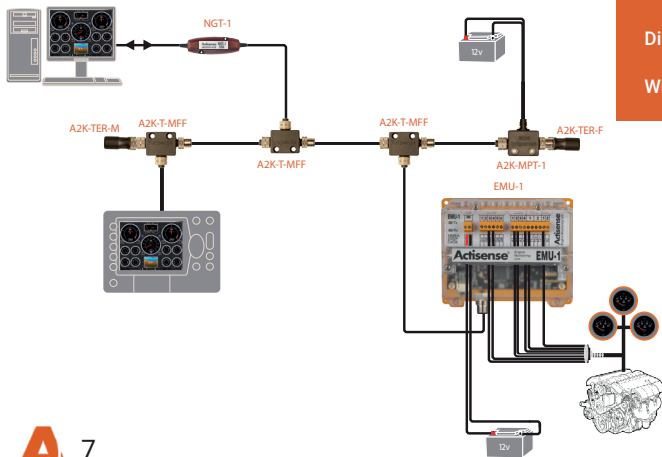

Interface your PC to the NMEA 2000® bus.



Benefits

- Allows all major PC Chartplotter applications to interface with the NMEA 2000 bus
- Provides a rule-enforcing firewall between the PC and the NMEA 2000 bus
- Powerful diagnosis of the NMEA 2000 network using the FREE NMEA Reader software provided
- Configure and flash-update Actisense products on the bus

The NGT-1 is an intelligent NMEA 2000 gateway able to precisely Transfer messages to and from the NMEA 2000 bus. It is compatible with a wide range of Chartplotters, display and configuration applications available for PCs.

The diagnostic NMEA Reader software allows viewing of NMEA 2000 messages with configuration options, enabling some set-up of Actisense products on the NMEA 2000 bus.

The firewall feature enforces the NMEA 2000 bus rules, so software developers can create compliant software at a fraction of the direct certification costs. The supporting Actisense Software Development Kit (SDK) helps to reduce the required development time.

Features

Vital NMEA 2000 diagnostic tool

USB version is fully isolated to prevent dangerous ground loops

ISO version has OPTO-isolated input and ISO-Drive™ output for safely interfacing with NMEA 0183 or RS232 / RS422

Up to 230,400 baud data transfer rate

Integrated 1.5m drop cable

Diagnostic receive LEDs

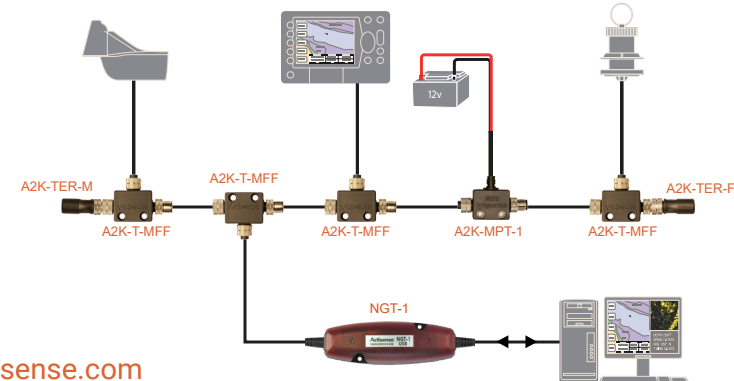



NGW-1 NMEA 2000® Gateway

Part Numbers: NGW-1-ISO
NGW-1-USB
NGW-1-ISO-AIS
NGW-1-STNG



QNB-1 Quick Network Block

Part Numbers: QNB-1
QNB-1-PMW

Hook up to NMEA 2000 whilst keeping currently installed NMEA 0183 devices.

The NGW-1 provides an uncomplicated way to link between a boat's data networks and converts NMEA 0183 data into NMEA 2000 data and vice-versa.

Multiple NGW-1 units can be used to multiplex numerous NMEA 0183 devices onto the NMEA 2000 network, using the network as a means of combining and transferring all data from one place to another.

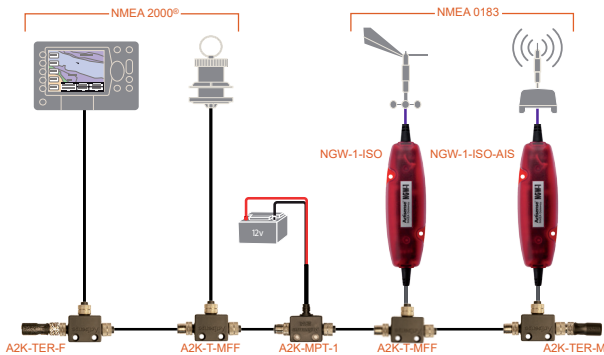

Benefits

- Upgrade NMEA 0183 equipment to NMEA 2000
- Allow NMEA 0183 devices to receive vital NMEA 2000 data
- Use the NMEA 2000 bus to multiplex several NMEA 0183 signals together
- Reliable, renowned bi-directional conversion engine
- Supports a wide range of conversions including AIS
- Easily configurable using Actisense Toolkit

Features

Fully isolated NMEA 0183 incorporating ISO-Drive™ technology

Advanced configuration using Actisense Toolkit allows Tx / Rx lists and Tx rates to be set

Supports Fast Heading at 10Hz

Up to 230,400 baud data transfer rate

Integrated 1.5m drop cable

Diagnostic receive LEDs



Fault-free, NMEA 2000® backbone connections.

The QNB-1 and QNB-1-PMW provide alternatives to multiple connectors, reducing the cost of an NMEA 2000 cable installation. Perfectly suited to areas of high instrument density, as six drops can be connected.

The LEDs provide information for the installer during set up and to indicate the presence of data, power status, power reversal and to show whether the fuses are intact.

The QNB-1-PMW version is fitted with six standard NMEA 2000 M12 (micro) female connectors allowing 'plug and play' connections for quick and easy installation.

Benefits

- One unit provides six NMEA 2000 drops
- Power feed is split to enable longer networks
- Separate fusing for split power feed provides an easy way to isolate network segments
- Simple installation on Mini and Micro networks using bulk cable
- Easy to mix & match NMEA 2000 with Raymarine STNG on opposite sides

Features

High quality NMEA 2000 barrier strip connections

Diagnostic LEDs

Uses standard ATO fuses

QNB-1-PMW

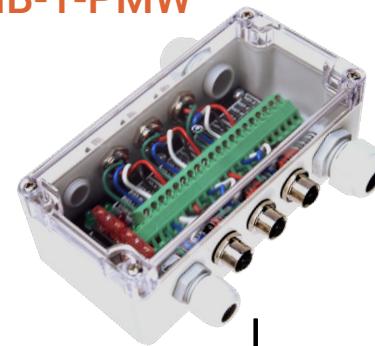

QNB-1

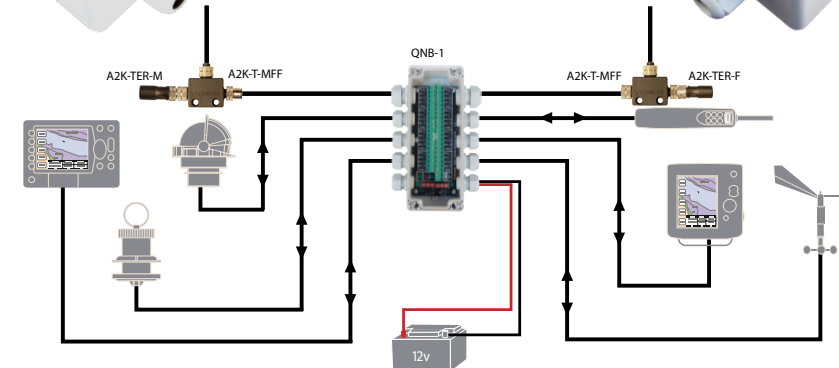
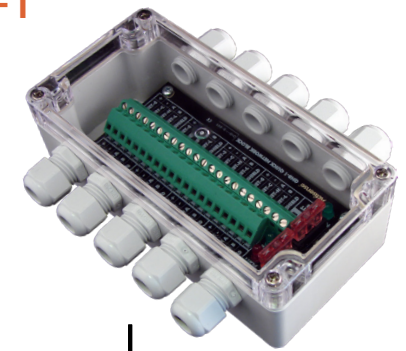

Integrate seamlessly with Raymarine® products

The STNG-A06045 adaptor cable enables users to integrate Raymarine SeaTalk^{NG} products into the standard configured NMEA 2000 bus and vice-versa. Currently only available when purchased with an Actisense NMEA 2000 Device



A pre-configured version is available for AIS conversions (NGW-1-ISO-AIS).

At Actisense we develop software tools to enable users to configure their system plus diagnose potential network problems quickly and easily.

NMEA Reader is a vital diagnostic tool that allows you to view and record information from NMEA 2000 or NMEA 0183 networks.

EBL Reader allows log files recorded by NMEA Reader and Actisense Toolkit to be viewed, analysed, filtered and exported helping users diagnose network issues and connection problems.

Actisense are continuously updating and releasing new tools and features to help users get the most out of their Actisense products.

ActisenseComms SDK Access

For further information about the ActisenseComms SDK please visit the website www.actisense.com/sdk

Please contact the Support Team at support@actisense.com, to discuss your project requirements and obtain the passwords necessary to access the files.

How to get your software

Actisense software is freely available at www.actisense.com

A solution for Mac, Linux and embedded developers is available but will require an NDA to be signed.



NMEA Reader

The NMEA Reader PC software allows NGT-1 owners to view NMEA 2000 data directly from the NMEA 2000 network, helping users to identify potential problems.

It breaks down the unreadable binary NMEA 2000 messages into easy to read parameter values. You can also display NMEA 0183 information, either through the USG-2 (see page 28) or any other safe connection to a PC.

This powerful diagnostic tool helps the user to understand and identify exactly which devices are active on the NMEA 2000 network (providing the details of each one) and what data they are sending.

EBL Reader

The EBL Reader utility software allows EBL files recorded by NMEA Reader and Actisense Toolkit to be viewed and analysed.

These recorded data files enable basic diagnostics and analysis of NMEA 2000 and NMEA 0183 networks to be performed.

Further processing can be performed by exporting filtered and decoded data to Excel spreadsheet

Log files can be analysed by the installer and also sent to Actisense support to aide a support ticket.

Features

Receives and displays NMEA 2000 messages

Receives and displays NMEA 0183 sentences

Provides detailed field data information on the currently selected message

View multiple connections simultaneously

Record log files of received data as EBL files for viewing and analysing with EBL Reader at a later date

Change the Device & System instances, plus installation details of NMEA 2000 devices

Actisense Toolkit

Actisense has developed Toolkit to respond to many highly requested features from its customers.

All devices on an NMEA 2000 network can be viewed in Toolkit, allowing quick identification of what installed devices are operational on the NMEA 2000 network (and potentially those that are not). Other useful product information can be viewed such as installed firmware version to help easily identify if a device is up to date.

NMEA 2000 data can be recorded for later analysis using EBL Reader. A future update to Toolkit will support a live data view making the Actisense Toolkit an 'all-in-one' configuration and diagnostics utility. Until this update is available, the Actisense NMEA Reader can show live data.

Features

View all operational NMEA 2000 network devices and their device properties

Record NMEA 2000 data for later analysis in EBL Reader

Configure EMU-1 and NGW-1

Save EMU-1 and NGW-1 configurations to a file for use later

Upgrade & downgrade EMU-1, PRO-BUF-1, PRO-MUX-1 and NDC-5 firmware

Change the Device & System instances, plus installation details of NMEA 2000 devices

Features

Displays log files saved by NMEA Reader and Actisense Toolkit of time-stamped NMEA 0183 or NMEA 2000 data

Provides detailed information on selection

Displays text files of NMEA 0183 sentences

A2K Range NMEA 2000® Networking



Our range of NMEA 2000 Micro connectors and cables has been designed using our specialist NMEA knowledge.

The 'A2K' range is carefully developed alongside our other products to ensure optimum performance and compatibility is maintained.

This careful design is visible throughout the A2K range. For example, the size of the T-piece was chosen to still allow field-fit connectors to be used with it when mounted to the bulkhead.

What is DeviceNet?

DeviceNet is the standard adopted by the NMEA for the cables and connectors (referred to as the 'physical layer') used for NMEA 2000 networking. The DeviceNet standard was already in use in automotive and agricultural industries when adopted by the NMEA and is proven to be very robust.



A A2K Range



Self-contained Boat Network (4 Way Drop)

- Built in terminators
- 3m UL Power cable
- Part Number: A2K-SBN-1

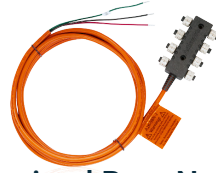

Self-contained Boat Network (8 Way Drop)

- Built in terminators
- 3m UL Power cable
- Part Number: A2K-SBN-2



Terminators (Micro)

- Male & Female connections
- Part numbers: A2K-TER-F A2K-TER-M



Dual Ended Cable Assemblies (Micro)

- Part numbers: A2K-TDC-0M25 A2K-TDC-0M5 A2K-TDC-1M A2K-TDC-2M A2K-TDC-3M A2K-TDC-4M A2K-TDC-5M A2K-TDC-6M A2K-TDC-8M A2K-TDC-10M



Power T (Micro)

- 3m UL Certified cable
- Part number: A2K-MPT-1

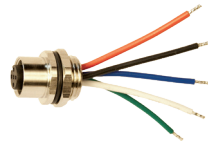

Panel Mount Connections (Micro)

- Male & Female connections, waterproof seals
- Part numbers: A2K-PMW-F A2K-PMW-M



Field Fit Connectors

Straight & right angled Male or Female field fit connectors (Micro).

- Part numbers: A2K-FFC-SF A2K-FFC-SM A2K-FFC-RF A2K-FFC-RM



T Piece (Micro)

- 2 Female and 1 Male connector
- Part number: A2K-T-MFF



4 Way Multidrop T Piece

- 5 Female and 1 Male connector
- Part number: A2K-4WT



4 Way Drop (Micro)

- 4 Female and 1 Male connector
- 2m UL Certified cable
- Part number: A2K-4WD-1



Gender Changer Cable (Micro)

- Female to Female and Male to Male connectors
- 0.25m cable
- Part numbers: A2K-GCF-0M25 A2K-GCM-0M25



Bulk (Light) Cable Reel 100m

- Part number: A2K-BULK-100M



Starter Kits (Micro)

Part number:	Contents:
A2K-KIT-1	1 x A2K-MPT-1 1 x A2K-TER-F 1 x A2K-TER-M 2 x A2K-T-MFF 1 x A2K-TDC-2M
A2K-KIT-2	1 x A2K-MPT-1 1 x A2K-TER-F 1 x A2K-TER-M 2 x A2K-T-MFF 1 x A2K-TDC-6M
A2K-KIT-3	1 x A2K-MPC-1 1 x A2K-TER-F 1 x A2K-TER-M 1 x A2K-4WT

Actisense products have always been developed to be robust and highly reliable. This same standard of design and build quality is being used to produce a product range aimed specifically at the larger vessel and commercial market.

Using the same knowledge and technical expertise we have applied to our NMEA 0183 and NMEA 2000 product ranges, we have now developed the Actisense Pro Range. The Pro products offer the same high quality and intelligent design expected from Actisense on a larger scale.

Pro products offer increased flexibility, with more inputs and outputs. Our OPTO-Isolation technology and ISODrive™ are built in as standard. The introduction of Ethernet and on-board web server enables easy browser based configuration. This makes our Pro Range some of the most adaptable products available today.

What is ISO-Drive™?



ISO-Drive™ technology is unique to our products and ensures each 'Talker' output is protected. ISO-Drive™ provides an isolated output, making installation simple and free from ground loops. This substantially reduces the risk of damage and hazards in connected equipment.

The ISO-Drive™ output is compatible with all connection types (RS422, RS485 & RS232), making for easy installation of an NMEA 0183 data bus system.

Outputs are separately isolated from each other and the input (Listener) circuit and can 'float' safely up to 1500 volts D.C from system ground.



A PRO-BUF-1

Professional NMEA 0183 Intelligent Buffer

Part Numbers: PRO-BUF-1-BAS-R
PRO-BUF-1-BAS-S

Adaptable NMEA 0183 Buffer with a variety of operating modes. Provides two OPTO-isolated inputs and twelve ISO-Drive™ outputs, keeping devices safe from hazardous ground loops.



PRO-BUF-1 is reliable, robust and provides isolation on all inputs and outputs as standard. With two NMEA 0183 inputs, twelve NMEA 0183 outputs, a bi-directional serial port and an Ethernet port, the PRO-BUF-1 is a perfect solution for larger leisure vessels and commercial shipping.

The PRO-BUF-1 is designed to suit the majority of NMEA 0183 systems and ready to go 'out of the box' by simply hard-wiring the two mode inputs as required. The manually configurable basic modes of operation include variations of buffer modes, autoswitch modes, and combine modes.

For all other configurations, leaving the mode inputs floating selects the 'User Configuration Mode'. The web browser based configuration tool allows full customisation of the PRO-BUF-1, and is compatible across all popular Operating Systems. The PRO-BUF-1 supports a direct Ethernet connection to a PC without the need for a specialised Ethernet crossover cable.

To make installation quick and simple the PRO-BUF-1 features 2-part pluggable connectors that allow use of screw or screwless terminals, and a professional DIN rail mounting mechanism (DIN rail included).

Benefits

- Quick and easy to install
- Works out of the box with pre-defined operating modes
- Configuration using standard web browser, no PC operating system compatibility issues
- Fully isolated with ISO-Drive technology for peace of mind
- Easy firmware updates makes the device future-proof

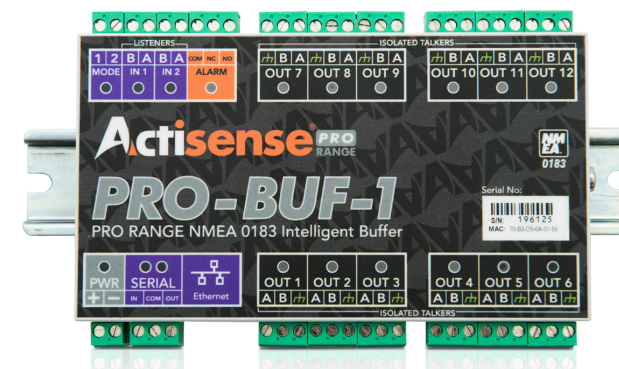

Features

- 2 OPTO-isolated NMEA 0183 inputs
- 12 ISO-Drive™ NMEA 0183 outputs
- Bi-directional isolated serial port (can be used for additional NMEA 0183 input/output)
- Ethernet port
- Alarm output (N/O and N/C contacts)
- Designed for 12 and 24 Volt supply
- Isolation to battery supply
- Browser based configuration tool
- Automatic baud rate matching on inputs
- Independently configurable outputs Provides data combining and autoswitching of inputs
- Alarm and Mode LED's
- 2 part pluggable connector system supports both screw and screwless terminals
- DIN rail or Panel mountable
- Advanced statistics are available via a Web Browser

Connector types:



R - Screw Terminals (Rising Clamp)



S - Screwless Terminals



Use with USBKIT-PRO for USB connectivity

Product Code	Description
PRO-BUF-1-BAS-R	Standard configuration with pluggable screw terminals
PRO-BUF-1-BAS-S	Standard configuration with pluggable screwless terminals

A PRO-MUX-1

Professional NMEA 0183 Multiplexer

Part Numbers: PRO-MUX-1-BAS-R
PRO-MUX-1-BAS-S

The PRO-MUX-1 is reliable, robust and provides industry leading isolation on all inputs and outputs as standard, so that connected devices safely avoid hazardous ground loops, the number 1 cause of product failure in NMEA 0183 networks.

PRO
RANGE

The eight NMEA 0183 inputs can be routed to any of the six NMEA 0183 outputs, providing a highly customisable network. A bi-directional serial port and an Ethernet port allow for simple configuration and diagnostics using Actisense software.

The configuration tool is accessible via any popular web browser (using the Ethernet port) so there are no PC operating system compatibility issues to contend with. Using the web based configuration tool will allow the user to finely tune the exact data available on each output. The default setup is for all data to go to all outputs.

2-part pluggable connectors on the PRO-MUX-1 (screw or screwless terminals available) mean that new devices can easily be installed without the need to remove the PRO-MUX-1 from its mounted location. A professional DIN rail mounting mechanism keeps the PRO-MUX-1 secure in high vibration environments. Helpful LEDs indicate power, data in, data out and the alarm status to aid diagnostics.

Benefits

Quick and easy to install

Configuration using standard web browser, no PC operating system compatibility issues

Advanced features solve NMEA 0183 data routing problems

Fully isolated with ISO-Drive technology for peace of mind

Easy firmware updates makes the device future-proof



Features

8 OPTO-isolated NMEA 0183 inputs

Isolation to battery supply

Diagnostic LEDs on all inputs and outputs

6 ISO-Drive NMEA 0183 outputs

Configurable input and output baud rates for rate conversion

Alarm, mode and Bi-colour Status LED's

Bi-directional isolated serial port (can be used for additional NMEA 0183 input/output)

Data combining from any input to any output

2 part pluggable connector system supports both screw and screwless terminals

Ethernet port

2 independent Autoswitch virtual inputs with priority

DIN rail or Panel mountable

Alarm output (N/O and N/C contacts)

Advanced sentence based filtering / routing

Advanced statistics are available via a Web Browser

Designed for 12 and 24 Volt supply

Connector types:

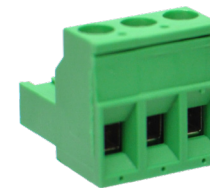

R - Screw Terminals (Rising Clamp)

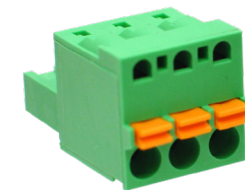

S - Screwless Terminals



Use with USBKIT-PRO for USB connectivity

Product Code	Description
PRO-MUX-1-BAS-R	Standard configuration with pluggable screw terminals
PRO-MUX-1-BAS-S	Standard configuration with pluggable screwless terminals

You can be assured our NMEA 0183 product range is built to last. Our robust, high quality, intelligent designs surpass the NMEA 0183 specifications.

Actisense NMEA interfaces enable users to get the most out of their instruments and on-board PCs.

Our NMEA 0183 products use ground breaking ISO-Drive technology along with OPTO-isolated inputs to protect both the NMEA 'Talker' devices and the Actisense product from ground loops and power spikes. They also feature high quality connectors making installation quick and simple.

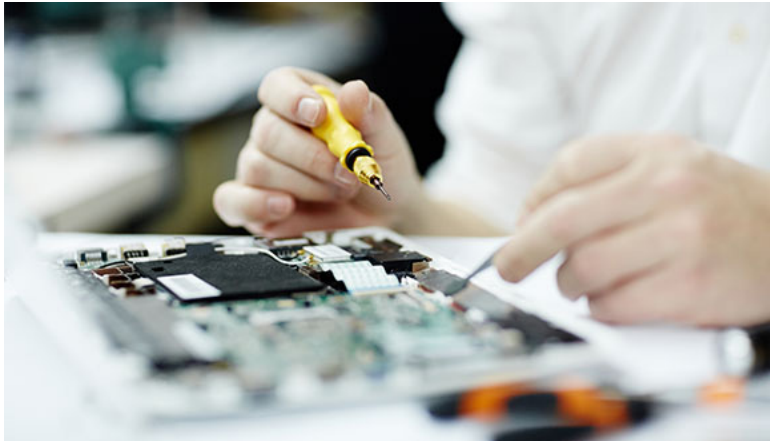

What is NMEA 0183?

NMEA 0183 is the original protocol for sharing data between marine electronic products and forms the foundation for defining electrical signalling, data protocol and sentence formats in the Marine Industry, making it possible to create a data bus to share information between devices from different manufacturers. Devices on the data bus are either 'Talkers', 'Listeners' or both and most operate at the default rate of 4800 baud.

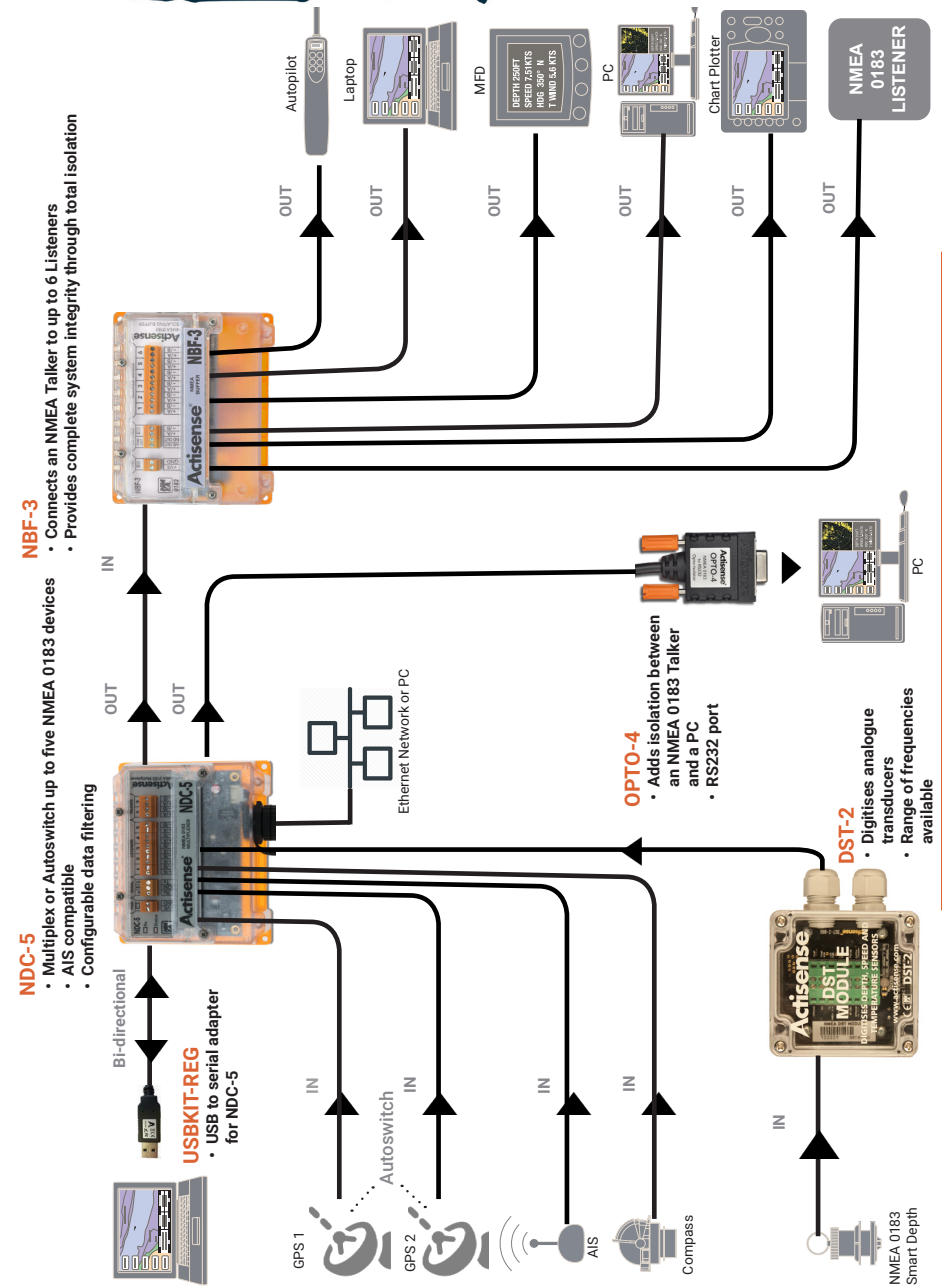

- NDC-5**
 - Multiplex or Autoswitch up to five NMEA 0183 devices
 - AIS compatible
 - Configurable data filtering
- NBF-3**
 - Connects an NMEA Talker to up to 6 Listeners
 - Provides complete system integrity through total isolation

- OPTO-4**
 - Adds isolation between an NMEA 0183 Talker and a PC
 - RS232 port

- DST-2**
 - Digitises analogue transducers
 - Range of frequencies available

The following products have our ISO-Drive™ technology built in:

- NDC-5
- NBF-3
- USG-2



NDC-5 NMEA Multiplexer

Part Number: NDC-5



NBF-3 NMEA Buffer

Part Number: NBF-3

The NDC-5 is more than just an NMEA 0183 Combiner/Multiplexer; it provides an installer with a highly flexible platform that can be used to solve many NMEA 0183 interconnectivity headaches.

Powerful routing allows any of the inputs to be routed to any output, combining data if required. Advanced features allow data rate conversion, auto-switching and advanced sentence based routing and blocking.

The configuration tool is accessible via any popular web browser using the Ethernet port, which supports both direct and network connections. Industry leading isolation is provided on all inputs and outputs as standard so that connected devices safely avoid hazardous ground loops, the number one cause of product failure in NMEA 0183 networks. This makes the NDC-5 robust enough to handle any NMEA 0183 installation.

Pluggable connectors allow new devices to be easily installed without the need to remove the NDC-5 from its mounted location. An optional professional DIN rail mounting mechanism keeps the NDC-5 secure in high vibration environments. Integrated LEDs provide feedback on basic status while advanced statistics are available via a Web Browser.

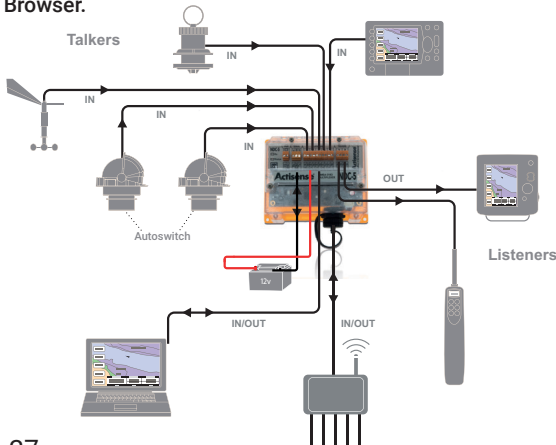

Benefits

- Quick and easy to install
- Configuration using standard web browser, no PC operating system compatibility issues
- Advanced features solve NMEA 0183 data routing problems
- Fully isolated with ISO-Drive technology for peace of mind
- Easy firmware updates make the device future-proof

Features

- 5 OPTO-Isolated NMEA 0183 inputs
- 2 ISO-Drive NMEA 0183 outputs
- Dedicated bi-directional Serial port (fully isolated utilising ISO-Drive technology)
- Serial port can be used as additional input / output
- Ethernet port supports direct and network connection
- Configurable input and output baud rates
- Allows Data combining and rate conversion
- 2 independent Autoswitch virtual inputs with priority
- Isolation to battery supply
- Diagnostic LED's
- IP65 rated Polycarbonate housing
- Optional DIN rail mount

www.actisense.com



Safely drive up to six NMEA Listeners, with power distribution for the connected Talker.

The NBF-3 NMEA Buffer isolates and buffers NMEA 0183 data, with the power to drive multiple devices.

Able to distribute up to six identical, amplified streams of data from one source. The NMEA signals are buffered to ensure that each Listener receives the data at the required voltage levels, providing consistent data quality.

Isolation on the input and outputs ensures the protection of the source Talker device and Listening devices.

ISO-Drive™ technology on the outputs and OPTO-isolation on the input enables you to connect the NBF-3 with complete peace of mind.

The NBF-3 has the addition of power distribution for the NMEA Talker. By having power and data from the same source, cabling requirements are reduced and installation is made simpler.

Benefits

- AIS compatible
- Protects connected devices
- Simple installation

Features

- One OPTO-isolated input
- Six ISO-Drive™ outputs
- Compatible with RS422, RS232 and RS485 connections
- Pluggable screw terminals
- Power and input indicator LEDs
- Power feed (500 mA) for single cable installations to the NMEA Talker
- Optional DIN rail mount
- Up to 115200 baud
- Outputs automatically track the input baud rate
- Protocol independent

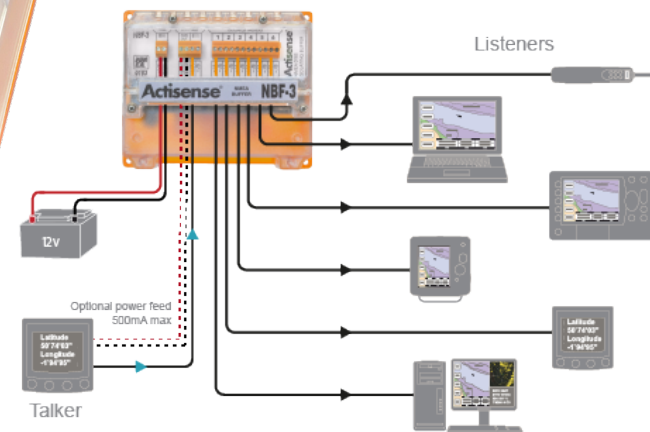

www.actisense.com

The USG-2 ensures safety and reliability when connecting a PC to your NMEA 0183 network.

The USG-2 converts a USB port into a bi-directional serial port suitable for connecting to a marine standard NMEA 0183 data bus.

It provides a far safer connection when compared to standard USB to serial converters.

Electrical isolation is provided by the ISO-Drive™ output and OPTO-isolated input making installation simple and free from ground loops.

The input uses the Actisense OPTO-isolation circuitry to protect any connected equipment from the most common system faults. The input can receive very low level signals that are often too small to be received by a PC serial port.

The USG-2 is the *safest* way to connect a boat's data network to an on-board PC.



Benefits

- Inputs & outputs protected against over voltage, ESD & short circuits
- Simple installation
- Protects PC from damage
- Eliminates ground loops

Features

NMEA 0183, RS422 & RS232 compatible

ISO-Drive™ technology

Pluggable screwless connector with locking latch & strain relief

Encapsulated electronics

High retention USB socket

Diagnostic & power LEDs

Baud rates from 300 to 230400 bps

Bulkhead mount, with optional DIN rail mount kit

Pluggable screwless connector



Breathe new digital life into transducers, with digital signal processing technology.



Benefits

- Use with most NMEA 0183 displays
- Can be calibrated
- Trip data available with speed transducers
- Designed to replace outdated stand-alone echo sounders
- General survey firmware available

Features

Range of transducer frequencies available

Flash upgradable 'future proof' design

Generates the echo sounders 'ping' and analyses the returned signal

Digitises analogue signals into NMEA 0183 data

The DST-2 digitises depth, speed and temperature transducer signals into NMEA 0183 data to deliver best-in-class seabed tracking.

It works with NMEA 0183 compatible devices, such as chart plotters, radars or an on-board PC. In addition, it can be calibrated via a PC to match various sensors and installations.

The DST-2 can be used with new or existing transducer installations. When used with an existing transducer the DST-2 can provide a secondary depth sounder as a back up to a new sonar system.

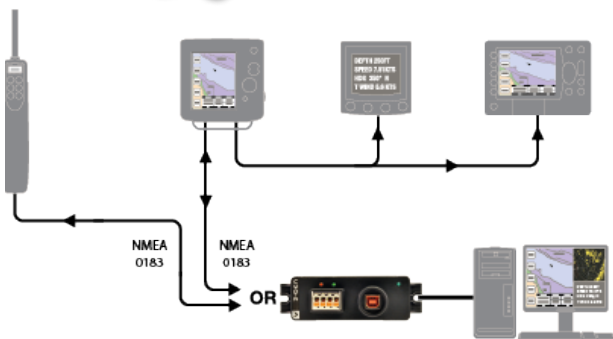

Analogue to NMEA 0183

Listeners

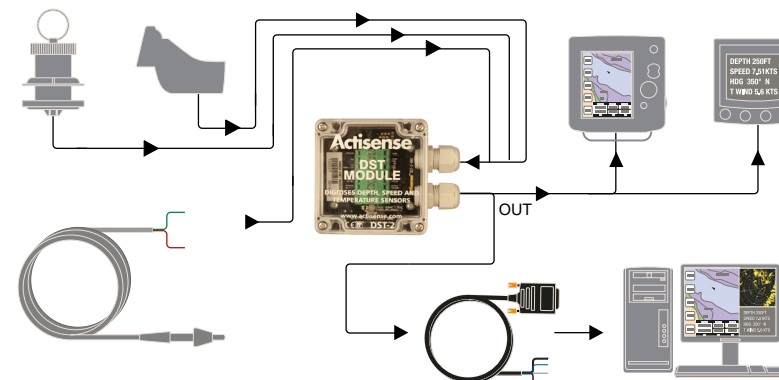

Isolate an RS232 (PC) port to protect against ground loops.

The OPTO-4 provides a safe and low cost way of connecting an NMEA 0183 system to a PC or any other device with a standard RS232 9-pin port.

As a bi-directional NMEA 0183 to RS232 interface cable, the OPTO-4 utilises OPTO-isolation to protect the PC input and spike protection for the PC output, providing comprehensive isolation of PC hardware when connecting to an NMEA 0183 bus.

If isolation in both directions is required, the Actisense USG-2 offers bi-directional isolation in a USB to RS422 (NMEA 0183) form (see page 12).

The Actisense design integrates an over-moulded case for excellent water resistance and a small footprint for installation into tight spaces.

Benefits

- Protects PC from damage
- Water resistant cable.
- Ruggedized overmoulded case suitable for harsh environment
- Quick and easy to install

Features

- One OPTO-isolated input
- One NMEA output
- Up to 115200 baud
- Port powered
- Shielded cable and case

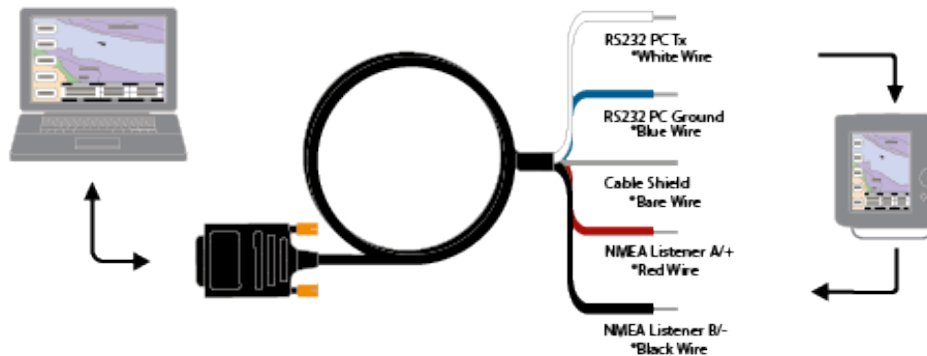

Product Accessories

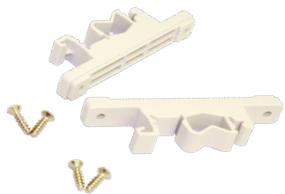

A-DIN-KIT-1

DIN rail mounting kit for use with NBF-3, EMU-1 and NDC-5.



A-DIN-KIT-2

DIN rail mounting kit for use with USG-2.

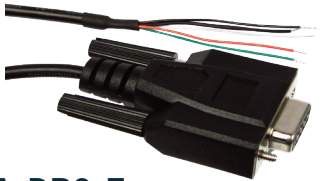

A-DB9-F

9 pin, D type moulded cable assembly



STNG-A06045

SeaTalk NG to NMEA 2000 adaptor cable (drop). Only for purchase with Actisense NMEA 2000 devices



A2K-SCREWCAP-10-F A2K-SCREWCAP-10-M

Protective SCREW cover for NMEA 2000 Micro connectors (in multiples of 10)



A-RJ45-FFC

Field fit connector for custom Ethernet cabling



A-USBKIT-REG

USB to Serial adapter for use with NDC-5



A-USBKIT-PRO

USB to Serial adapter for use with the PRO Ranges

“Some of the sharpest engineering minds in the industry and a relentless drive to innovate, Actisense has achieved a standard of quality and reliability most companies only hope for. Their innovative designs and top-quality manufacturing result in a broad range of solutions infused with durability and value. We are proud to share in their success and without hesitation, recommend Actisense products to our customers.”

Peter J. Braffitt
General Manager
GEMECO Marine Accessories